

THIS DRAWING IS UNPUBLISHED. RELEASED FOR PUBLICATION
 © COPYRIGHT BY TYCO ELECTRONICS CORPORATION. ALL RIGHTS RESERVED.

LOC	DIST	REVISIONS			
P	LTR	DESCRIPTION	DATE	DWN	APVD
G	14	G	REV PER 0G3A-0415-04	07JUN04	JT MJS

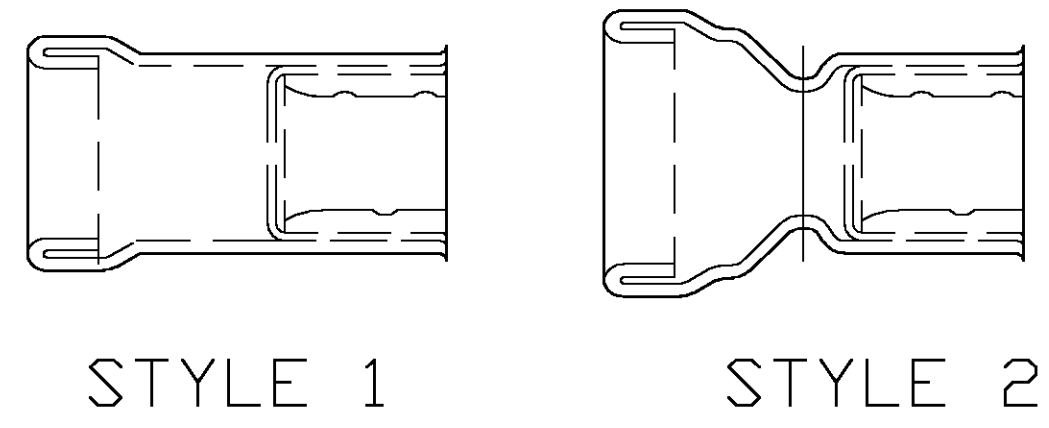
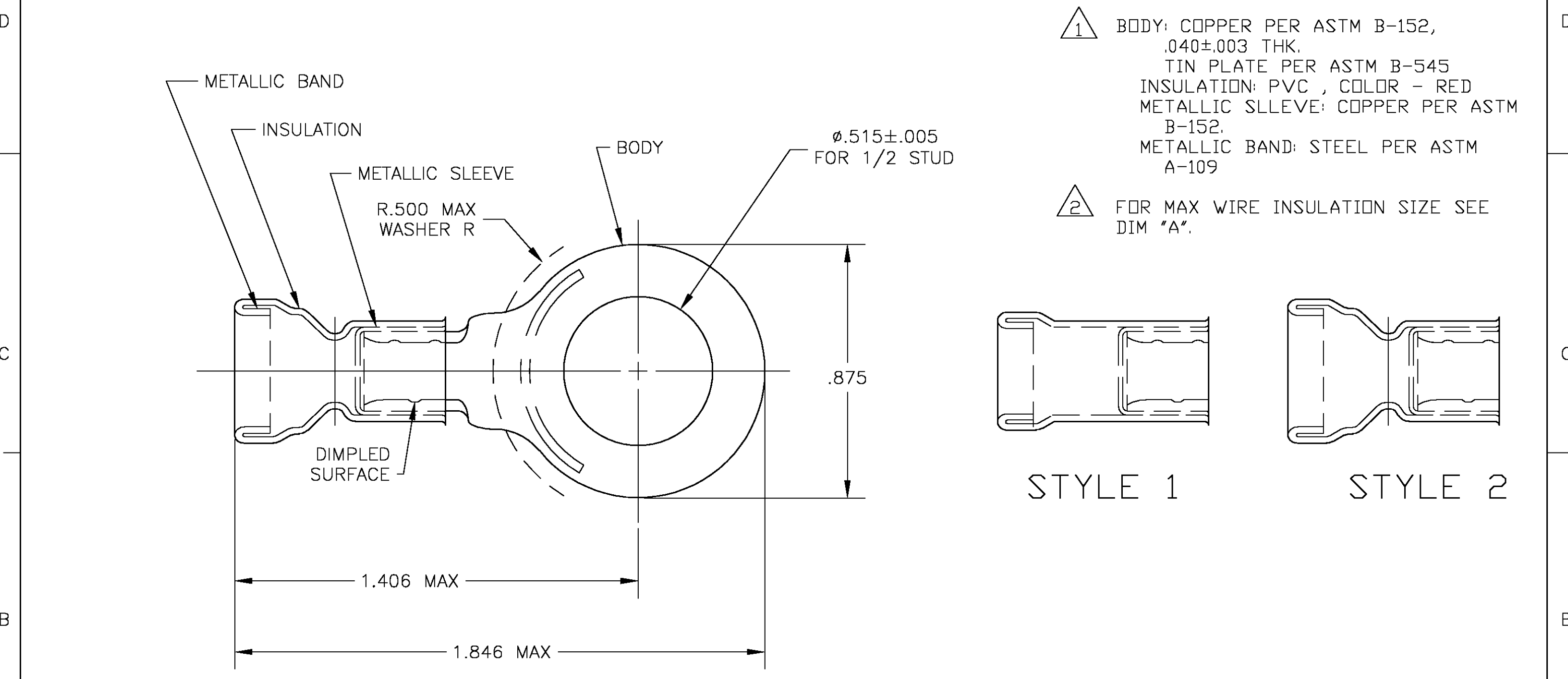

OBSOLETE	1	.377	2 328463-1
	2	.298	328463
	STYLE	DIM "A"	PART NO

THIS DRAWING IS A CONTROLLED DOCUMENT.		DWN jr_ruth 07JUN04	Tyco Electronics Corporation Harrisburg, PA 17105													
DIMENSIONS: INCHES		CHK MJ SPICER 07JUN04	NAME													
TOLERANCES UNLESS OTHERWISE SPECIFIED:		APVD MJ SPICER 07JUN04	WIRE TERMINAL AMPLI-BOND, RING TONGUE, WIRE SIZE : 8 AWG													
<table border="1"> <tr><td>0 PLC</td><td>± -</td></tr> <tr><td>1 PLC</td><td>± -</td></tr> <tr><td>2 PLC</td><td>± -</td></tr> <tr><td>3 PLC</td><td>± .008</td></tr> <tr><td>4 PLC</td><td>± -</td></tr> <tr><td>ANGLES</td><td>± 5'</td></tr> </table>		0 PLC	± -	1 PLC	± -	2 PLC	± -	3 PLC	± .008	4 PLC	± -	ANGLES	± 5'	PRODUCT SPEC	SIZE	CAGE CODE
0 PLC	± -															
1 PLC	± -															
2 PLC	± -															
3 PLC	± .008															
4 PLC	± -															
ANGLES	± 5'															
MATERIAL		APPLICATION SPEC	DRAWING NO	RESTRICTED TO												
- 1		WEIGHT	A3 00779	C-328463												
- 1		CUSTOMER DRAWING		SCALE 3:1 SHEET 1 OF 1 REV G												